

## RDA AHVP30-6M NA Manufacturers Series Positioner 3,000 lb capacity

Red-D-Arc's RDA AHVP30-6M NA positioners provide 360° rotation of a work piece along with 135° forward tilt to better position weldments for better down-hand or automatic welding. All-fabricated steel frames and bases support rotation and tilt spur-gears driven by worm-gear reducers to provide enhanced safety and durability. A remote hand pendant is used to control table-rotation direction and speed, and a stop-switch is included. The positioner-mounted control box has controls for table tilt as well as an e-stop control. Rotation motors are inverter-controlled variable-frequency AC-type, providing a full range of variable-speed control with excellent speed regulation. Red-D-Arc welding positioners are engineered to provide maximum safety and dependability and control boxes on M-series positioners have IP65-rated enclosures with full CE certification. The RDA AHVP30-6M NA's table can be set to one of three different table heights.

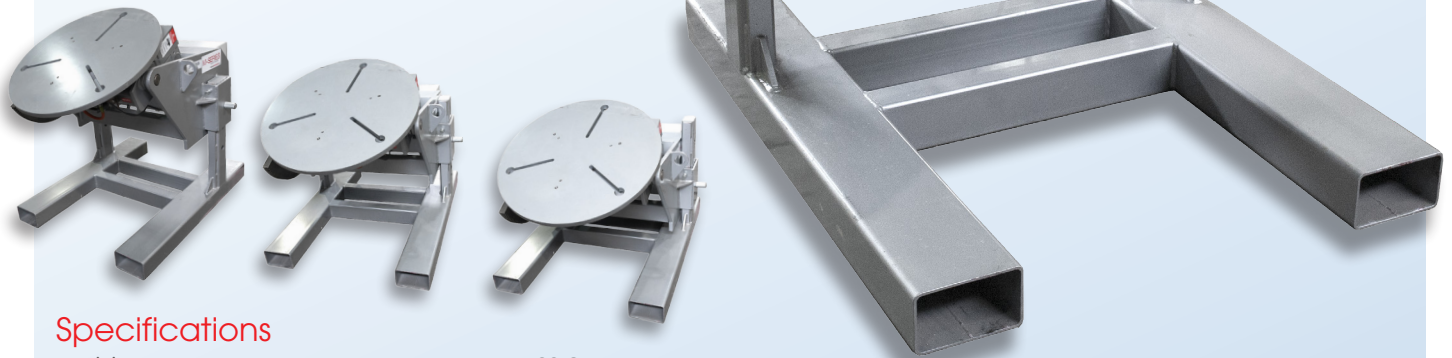

### Specifications

Model	RDA AHVP30-6M NA
Capacity	3307 lb (1.5 tonne) at 6 in (152 mm) C of G and 6 in (152 mm) eccentricity
Rotation Speed	0.07 - 1.4 RPM
Rotation Motor	0.75 kW inverter-controlled variable-frequency AC-type
Rotation Torque	19,525 in-lbs (2206 Nm)
Tilt	135° forward tilt in 30 seconds
Tilt Motor	0.75 kW with brake
Tilt Torque	39,050 in-lbs (4413 Nm)
Table Height (Horizontal)	33.7 in (855 mm), 39.6 in (1005 mm), 45.5 (1155 mm)
Table Diameter	36.2 in (920 mm) round with three 0.7 in (19 mm) slots
Hand Pendant Control	Forward/stop/reverse/variable-speed table rotation control with 20 ft control cable
Control Panel Functions	Tilt up/tilt down functions, e-stop and power on/off switch
Primary Input Power	110 V, 1 phase, 60 Hz
Input Current at Rated Load	4.6 A
Ground Capacity	300 A
Weight	1984 lb (900 kg)
Control Box Ingress Protection Rating	IP65
Options	Remote foot controls, various capacity gripper chucks



Red-D-Arc Welderentals, an Airgas company, rents and sells welding and weld-positioning equipment - around the world.

# RDA AHVP30-6M NA Manufacturers Series Positioner

3000 lb capacity

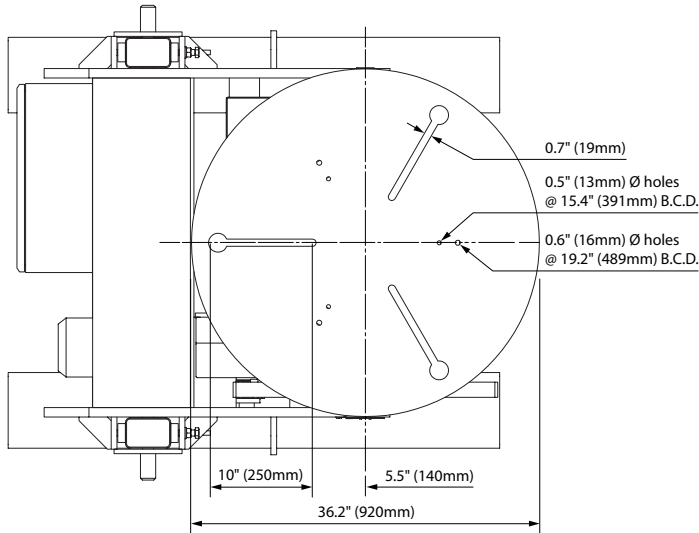

adjustable height

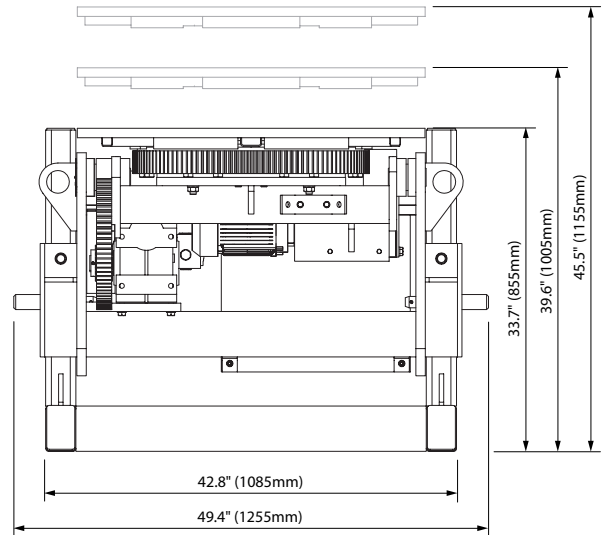
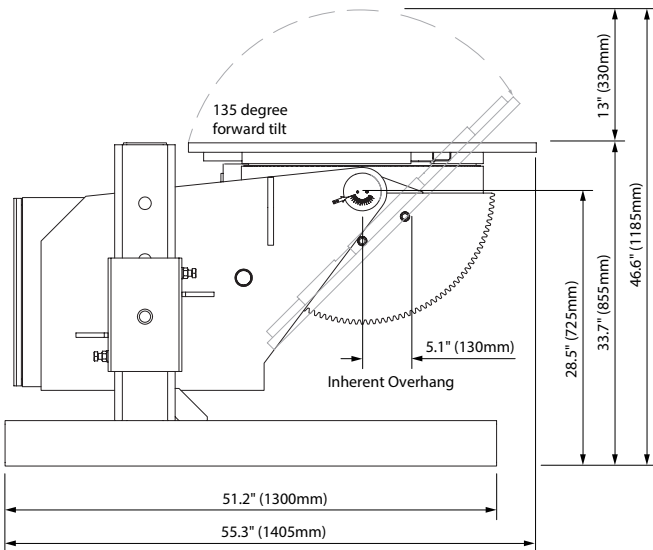

## Rotating

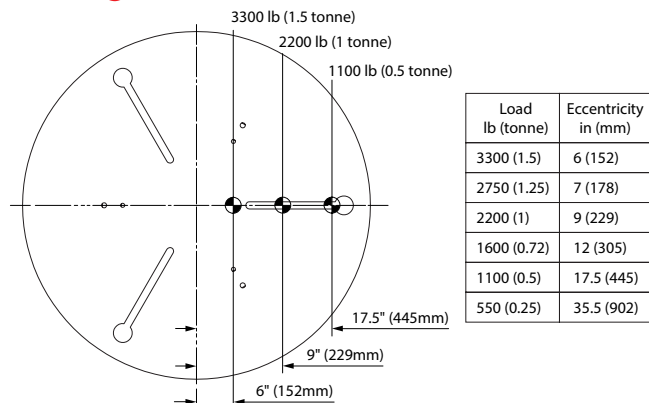

## Tilting

